



**Model(s): HDS-14 / HDS-14X / HDS-14TL**  
**Description: Medium-Duty Four-Post Lifts**

BendPak's "HDS-Series" four-post lifts are a whole new breed of rugged. They're newly engineered car and truck lifts that work better, are built to last, and feature upgrades that increase safety, durability and productivity.

The HDS-14, HDS-14X, and the Super-Tall HD-14TL four-post models provide a generous 14,000-lb. lifting capacity and feature extended runways to accommodate a wide variety of vehicle wheelbases.



**Features**

- Huge 10-1/2" diameter cable sheaves within the runway and cross tubes combined with massive 2-1/4" diameter sheave axles dramatically improve cable wear and critical component lifespan meaning you'll spend less money in service related expenses down the road. Dual-hub cable sheaves reduce stress, fatigue and wear.
- BendPak's HDS-Series lifts feature four 1/2" diameter 6 x 25 stainless-steel lifting cables that have a breaking strength of over 14,000 pounds each. This aircraft-quality cable was specifically designed for lifting applications and provides a great balance between abrasion resistance and fatigue.
- Grease nipples are located on every sheave and sheave axle to make lubrication maintenance a breeze.
- Each HDS-Series four-post is equipped with a single hydraulic cylinder hidden away under the runway for maximum performance and reliability and minimum exposure to elements. The hydraulic cylinder features a one-piece, pilot fitted, machined steel piston wrapped with high-durometer, mechanically loaded rod seals, pressure loaded U-cup piston seals, backups and wear bands that virtually eliminate any fluid bypass. The micro-smooth chrome-rod is machined from high yield, ground & polished C-1045/50 micro-alloy steel and plated to a minimum of .001½ diametrically, to ensure superior cylinder operation and life. The welded cylinder body is made from high strength steel tubing produced to exceed ASTM specifications. This combination of superb base material and superior processing ensures straight, smooth, cylinders that will provide years and years of dependable trouble-free service.
- An integrated hydraulic flow restrictor provides a controlled descent in the unlikely event of an unexpected hose rupture.



- A durable powder coat finish can withstand harsh environments and chemical spills and will provide years of protection. We take pride in our meticulous six-step process. (1) All parts are visually inspected then sandblasted. (2) All parts are washed in five-stage phosphate tanks then immediately dried, to avoid rusting. (3) All surfaces and/or threaded holes that need to be masked or plugged are done so with high-temperature masking tape and silicone plugs. (4) The parts are given a quick thinner wipe to remove any light debris or fingerprints. (5) Finished parts are hung on an electro-statically grounded conveyor line, then powder is applied using an electrostatic spray gun. (6) Once the parts are powder coated, the carts are rolled into our curing oven and baked at 400 degrees for 15 for 45 minutes.
- Spring-loaded safety locks automatically engage continuously during rise and adjustable safety ladders allow for precise runway leveling even when installed on sloped floors.
- A simple push-button pneumatic lock release makes lowering operations simple and fast. Aircraft-quality stainless steel and aluminum pneumatic cylinders will provide years of trouble-free service.
- A secondary lock system is on constant guard and acts as a slack-cable device in the unlikely event of an unexpected cable failure.
- Lifting cables, airlines, safety latches and sheaves are all fully enclosed within lift structure.
- Features multiple adjustable height locking positions for variable-height parking and infinite leveling.
- A maintenance-free electric hydraulic power system assures ultimate dependability.
- All operator controls are conveniently located within easy reach.
- 12" x 10" base plates provide a solid foundation.
- Non-skid runways provides maximum grip, even when the runway surface is wet or oily.
- Lifting cables, airlines, safety latches and sheaves are all fully enclosed.
- Extended length approach ramps help when loading low ground clearance vehicles.
- Optional 7000 pound capacity rolling jacks (model RJ-7) make a great addition to increase service capacity. RJ-7 bridge jacks are used to raise the front or rear portion of a vehicle off the runways allowing operators to perform efficient wheel and break service. A pair of jacks allows the entire vehicle to be elevated. Each jack has telescoping arms and frame contact pads that can be extended over the runways and positioned under vehicle lifting points. Telescoping rail supports accommodate adjustable runways for different tread widths. Each jack features three safety-lock positions and stackable truck and van adapters for increased lifting height and better access to frame contact points on high ground-clearance vehicles. The jacks come equipped with a commercial grade air-hydraulic pump requiring a maximum pressure of 125 PSI and 10-20 CFM.



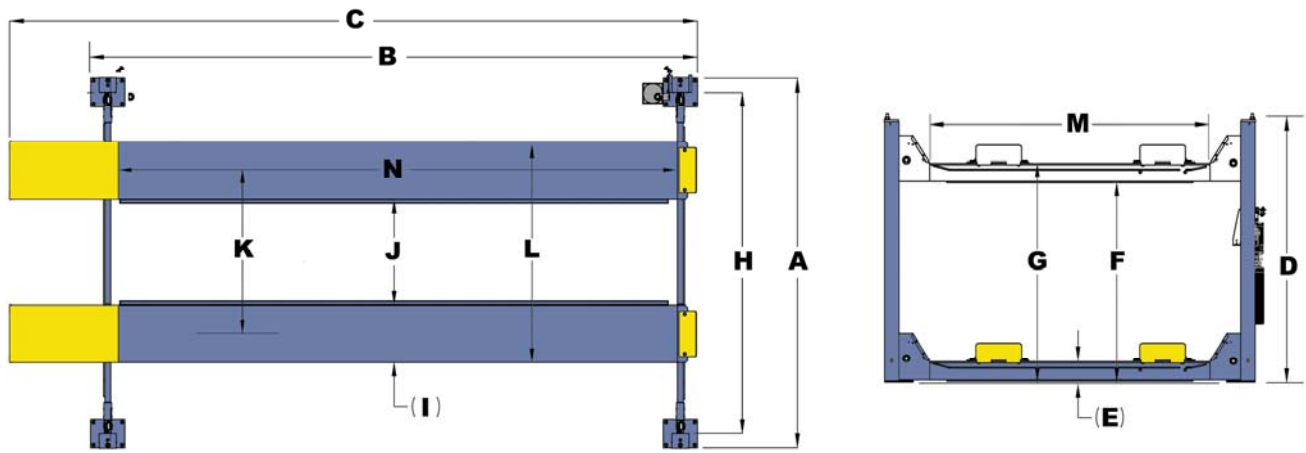

MODEL	HDS-14	HDS-14X	HDS-14TL
Lifting Capacity*	14,000 lbs. / 6350 Kg.	14,000 lbs. / 6350 Kg.	14,000 lbs. / 6350 Kg.
*Max Capacity / Front Axle	7,000 lbs. / 3175 Kg.	7,000 lbs. / 3175 Kg.	7,000 lbs. / 3175 Kg.
*Max Capacity / Rear Axle	7,000 lbs. / 3175 Kg.	7,000 lbs. / 3175 Kg.	7,000 lbs. / 3175 Kg.
A - Overall Width	130" / 3301 mm	130" / 3301 mm	130" / 3301 mm
B - Outside Length	213" / 5408 mm.	243" / 6170 mm.	213" / 5408 mm.
C - Overall Length	241" / 6131 mm	271" / 6893 mm.	241" / 6131 mm
D - Height of Columns	92" / 2338 mm.	92" / 2338 mm.	104" / 2642 mm.
E – Min. Runway Height	7-5/8" / 192 mm.	7-5/8" / 192 mm.	7-5/8" / 192 mm.
F – Max. Rise	70" / 1778 mm.	70" / 1778 mm.	82" / 2083 mm.
G - Max. Lifting Height	77-5/8" / 1970 mm.	77-5/8" / 1970 mm.	89-5/8" / 2276 mm.
H - Width Between Columns	120" / 3046 mm.	120" / 3046 mm.	120" / 3046 mm.
I - Runway Width	20" / 508 mm.	20" / 508 mm.	20" / 508 mm.
J - Width Between Runways (*) MIN	37-1/2" / 952 mm.	37-1/2" / 952 mm.	37-1/2" / 952 mm.
J - Width Between Runways (*) MAX	51" / 1295 mm.	51" / 1295 mm.	51" / 1295 mm.
K - Runway Centerline (*) MIN	57-1/2" / 1460 mm.	57-1/2"	57-1/2"
K - Runway Centerline (*) MAX	71" / 1803 mm.	71" / 1803 mm.	71" / 1803 mm.
L - Outside Edge of Runways (*) MIN	77-1/2" / 1968 mm.	77-1/2" / 1968 mm.	77-1/2" / 1968 mm.
L - Outside Edge of Runways (*) MAX	91" / 2311 mm.	91" / 2311 mm.	91" / 2311 mm.
M - Drive-Thru-Clearance	98" / 2482 mm.	98" / 2482 mm.	98" / 2482 mm.
N - Length of Runways	199" / 5054 mm.	229" / 5816 mm.	199" / 5054 mm.
Min. Wheelbase @ Rated Capacity	140" / 3556 mm.	170" / 4318 mm.	140" / 3556 mm.
Min. Wheelbase @ 75% Capacity	120" / 3048 mm.	145" / 3683 mm.	120" / 3048 mm.
Min. Wheelbase @ 50% Capacity	100" / 2540 mm.	120" / 3048 mm.	100" / 2540 mm.
Min. Wheelbase @ 25% Capacity	80" / 2032 mm.	95" / 2413 mm.	80" / 2032 mm.
Locking Positions	13	13	16
Lock Spacing	Every 4" / 102 mm.	Every 4" / 102 mm.	Every 4" / 102 mm.
Lifting Time	60 Seconds	60 Seconds	65 Seconds
Standard Motor (***)	220 VAC / 60 Hz. 1Ph.	220 VAC / 60 Hz. 1Ph.	220 VAC / 60 Hz. 1Ph.

\* This dimension may be limited with the addition of rolling jacks. See rolling jack specifications on separate page.

\*\* May vary depending on wheel size.

\*\*\* Special Voltages Available Upon Request.

The design, material and specifications are subject to change without notice.